

Ozone Systems

Installation & Operation Manual

Mobile Surface Washer

C Series



ClearWater Tech, LLC.
Integrated Ozone Systems

850-E Capitolio Way, San Luis Obispo, Ca 93401 • Ph: 805-549-9724 • Fax: 805-549-0306 • E-mail: service@cwtozone.com • www.cwtozone.com
Copyright © 2018 - ClearWater Tech, LLC • Reproduction of any kind is prohibited • LIT20 • REV 051420



INTRODUCTION

This Installation and Operation Manual is written to assist in the installation, operation and maintenance of ozone delivery systems manufactured by ClearWater Tech, LLC. This equipment has been designed using the most modern materials and technology available.

Please read this manual carefully and in its entirety before proceeding with any installation, operation or maintenance procedure associated with this equipment. Failure to follow these instructions could result in personal injury, damage to the equipment or reduced product performance.

In an ongoing effort to improve reliability and operating efficiency, ClearWater Tech may find it necessary to make changes to its products. Therefore, the information contained in this manual may not conform in every respect to earlier versions of ClearWater Tech ozone system found in the field. If you have any questions, please contact your ClearWater Tech dealer or the ClearWater Tech service department.

TABLE OF CONTENTS

Overview	3
Safety Information	4
Product Description	6
<i>Figure 1 – C Series Overview</i>	6
<i>Figure 2 – Control Panel</i>	7
Theory of Operation	10
Using the C Series	12
Using the C Series for surface disinfection.....	12
<i>Figure 3 – C Series in Side Stream Configuration</i>	13
Using the C Series for gas production.....	14
Using the C Series to sanitize barrels.....	14
Using the C Series to prepare barrels for storage.....	15
Using the C Series for room disinfection.....	16
Maintenance	17
<i>Figure 4 – Ozone Generator Cooling Fan Assembly</i>	18
<i>Figure 5 – Reaction Chamber – Exploded View</i>	20
Troubleshooting	21
Appendix A – Specifications	24
Appendix B – Parts List	29
Appendix C – Maintenance Kit	30
Appendix D – Logic Schematics	31
Appendix E – Drive Module Input Voltages	32
Appendix F – MSDS	33
Appendix G – Warranty Information	35

OVERVIEW

How Ozone Is Generated

Ozone is generated by exposing oxygen molecules (O_2) in an air stream to a controlled, high-energy electrical field. As the air stream passes through the electrical field produced inside the ozone generator, some oxygen molecules are split, forming single oxygen atoms (O_1). These oxygen atoms then recombine with other oxygen molecules in the air stream, forming ozone (O_3)

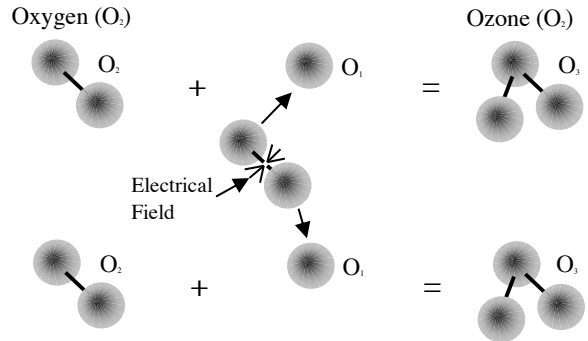

Properties of Ozone

Ozone is the most powerful oxidizer available that can be safely used in water treatment¹. It is used to treat drinking water, bottled water, swimming pool water, waste water, food and beverage processing water, and in many other applications. Ozone in gaseous form is used to treat organic contamination in the air, and treat surfaces. Ozone is effective in performing the following:

- **Disinfection** – Bacterial disinfection, inactivation of viruses and cysts.
- **Oxidation of Inorganics** – Precipitates, iron, manganese, sulfides nitrides and organically-bound heavy metals
- **Oxidation of Organics** – Including organics causing color, taste, and odor problems. Some detergents and pesticides, phenols, VOCs, turbidity control and micro-floccuity control and micro-flocculation of soluble organics.

Molecular Weight	48
Odor	Readily detectable at concentrations above 0.02 ppm in air
Color	Bluish in ozone generator cell, but ozone/air mixture exiting generator is invisible – even at high ozone concentrations.
Gas Density:	2.144 grams/liter at 32°F (Approximately 150% that of oxygen).
Solubility	Only partially soluble in water, but about 10-20 times more soluble than oxygen (at 68°F).

Benefits of Ozone Use



- Ozone is generated on site – no transportation or storage is required
- The most powerful oxidizer commercially available – very effective for disinfection and oxidation without handling problems.
- Ozone creates no potentially harmful by-products (such as THMs) – the only by-product is oxygen.
- Ozone leaves no telltale taste or odor.

¹ Water Quality Association, “Ozone for POU, POE and Small Water System Water Treatment Applications,” Lisle, IL, 1999

Safety Information

Safety Warnings

Two aspects of ClearWater Tech ozone generators represent potential dangers – ozone gas and high voltage electricity.

OZONE GAS – WARNING: HIGH CONCENTRATIONS OF OZONE GAS ARE DANGEROUS TO HUMANS. LOW CONCENTRATIONS CAN CAUSE IRRITATION TO THE EYES, THROAT AND RESPIRATORY SYSTEM.

This ClearWater Tech corona discharge ozone generator is designed to operate under a vacuum condition. While safety precautions have been taken, entering the equipment area should be avoided if ozone gas is detected. Ozone has a very distinctive odor and is detectable at very low concentrations (0.02 ppm), which is far below OSHA's maximum permissible exposure level of 0.1 ppm.



HIGH VOLTAGE – WARNING: CLEARWATER TECH OZONE GENERATORS OPERATE AT HIGH VOLTAGE. MAKE SURE UNIT IS UNPLUGGED BEFORE REMOVING ANY OF THE PANELS ON THE C Series. IF CONTACT IS MADE WITH OPERATING HIGH VOLTAGE COMPONENTS, ELECTRIC SHOCK WILL OCCUR.

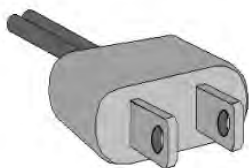

ClearWater Tech corona discharge ozone generators take line voltage and convert it to 48 VDC. A high voltage transformer then boosts the voltage. Proper care must be used by a qualified electrician when making any internal adjustments or performing any maintenance procedures.

IMPORTANT SAFETY INSTRUCTIONS

When installing and using this electrical equipment, basic safety precautions should always be followed, including the following:

- 1. READ AND FOLLOW ALL INSTRUCTIONS.**
- 2. SAVE THESE INSTRUCTIONS.**
3. Make sure ozone gas valve is set to the water mode unless ozone gas is desired and ozone line is run from the unit to where ozone gas is required.
4. Use caution when using the ozone gas feature.
5. Do not supply cart with heated water. Damage to the system may occur.
6. Do not allow the C Series system to be directly sprayed with water. Water spraying up underneath the C Series cart can be particularly damaging.

Product Description

The C Series Mobile Surface Washer Ozone System is an advanced ozone delivery system designed and engineered specifically with the food and beverage industries in mind. The C Series has multiple modes to provide versatility in various applications. In aqueous mode, the C Series takes water from a clean water source and provides ozone-containing water under pressure. In oxygen gas mode, the C Series can provide concentrated oxygen gas at the gas outlet. In ozone gas mode, the C Series can provide concentrated ozone gas at the gas outlet. The C Series provides easy to understand controls and status information to ensure proper operation.

C Series Overview

Figure 1

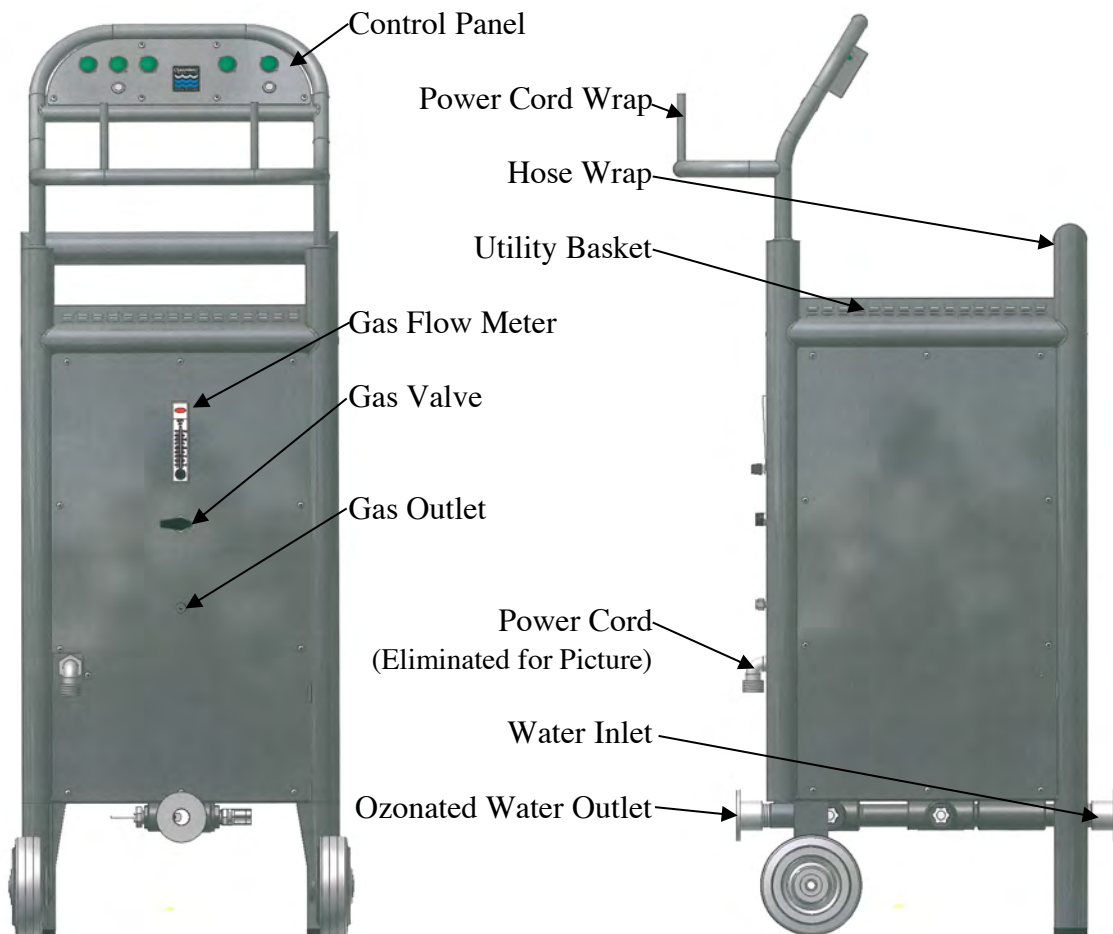

Control Panel

One of the primary goals in the design of the C Series is to provide the operator with state of art control and system indication. Using easy to see LED lamps and stainless steel push buttons the C Series makes sure the operator is always in control and informed.

The Power Button – This turns the system on and off. When the system is off, pushing the button will turn the system on. When the system is on, pushing the button will turn the system off. Holding down the power button while plugging the cart into power will reset the service timer.

Mode Button – When the system is on (see Power Button), pushing the mode button will cycle through the available modes. If the system is in Ozonated Water mode, and the button is pushed, the system will move to Oxygen Gas mode. If the system is in Oxygen Gas mode, and the button is pushed, the system will move to Ozone Gas mode. If the system is in Ozone Gas mode, and the button is pushed, the system will move to the Ozonated Water mode.

Control Panel

Figure 2

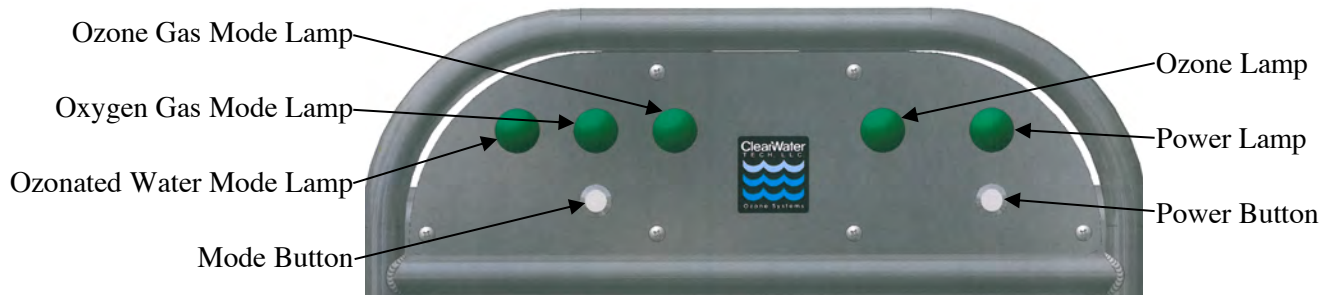

Power Lamp – This lamp is illuminated when the system is on. This lamp will not be illuminated when the system is off. This lamp will begin blinking when the system is in need of service.

Ozone Lamp – This lamp will be illuminated when ozone is being produced, whether in ozonated water or ozone gas modes.

Ozonated Water Mode Lamp – This lamp will be illuminated when the system is in Ozonated Water Mode. The lamp will begin blinking if no or insufficient flow of water is flowing through the system, or if the gas valve is in the “Gas” position. **Note: If water flow to or from cart is stopped, the pump will remain on for 2 seconds, the Ozone will remain on for 5 seconds and the Oxygen concentrator will remain on for five minutes. This feature allows the system to deliver Ozonated water when the water flow is being interrupted repeatedly during the use of a spray wand.**

Oxygen Gas Mode Lamp – This lamp will be illuminated when the system is in Oxygen Gas Mode. The lamp will begin blinking if the gas valve is in the “Water” position.

Ozone Gas Mode Lamp – This lamp will be illuminated when the system is in Ozone Gas Mode. The lamp will begin blinking if the gas valve is in the “Water” position.

Power Cord Wrap

On the handle bar two vertical posts have been provided that allow the power cord to be wrapped around for convenient storage.

Hose Wrap

The frame extends up on the back end of the C Series. This feature provides a convenient place to wrap hoses when they are not in use.

Utility Basket

The C Series is equipped with a utility basket with a drain in the middle for fittings, adaptors, etc. to be stored in one place. The drain allows excess water to safely go to the ground.

Gas Flow Meter

When in Oxygen Gas Mode, this gas flow meter shows the flow rate of the oxygen being supplied at the Gas Outlet. When in Ozone Gas Mode, this gas flow meter shows the flow rate of the ozone being provided at the Gas Outlet. The ball should be in the green zone. The needle valve on the meter is factory set but might need to be adjusted.

Gas Valve

The C Series can be provided with an ozone and oxygen gas feature, depending on the mode selected. This valve is a three-way locking valve for added safety. To move the valve the metal locking mechanism must be pushed in. To move the valve from one side to the other the valve must pass through the “Off” position. This feature is to prevent the valve from accidentally being moved. When in Oxygen Gas Mode, the cart can supply ~93% oxygen gas. When in Ozone Gas Mode, the cart can supply 18 g/h ozone gas (more or less depending on flow rate). When using the cart to provide gas output, this valve must be set to “Gas”. When using the cart to provide ozonated water, this valve must be set to “Water”. **Caution – Having this valve in the wrong position will result in the cart not producing ozone as a safety feature to protect the operator.**

Gas Outlet

When using the C Series to provide gas, this is the outlet where the gas will exit the cart. This is a Kynar push to connect ¼ inch tube fitting. The type of gas will depend on the mode that the C Series is in. When in Oxygen Gas Mode, the cart can supply ~93% oxygen gas at this outlet. When in Ozone Gas Mode, the cart can supply 18 g/h ozone gas (more or less depending on flow rate) at this outlet. **Note - When using the cart to provide gas output, the gas valve must be set to “Gas”.**

Power Cord

For operator safety, the C Series is designed with a Ground Fault Circuit Interrupt (GFCI) to the power cord. When the GFCI is working the indicator light on the GFCI will be illuminated and there will be power to the system. If the indicator is not illuminated, press the “Reset” button. If a longer power cord is needed, only use a grounded extension cord, 20 feet max, 12-gauge wire thickness minimum.

Water Inlet

The water inlet is a ¾ inch female pipe thread fitting. The C Series can come with an 1.5 inch Tri-Clover fitting already installed, or you can install whichever fitting that allows the C Series to be seamlessly integrated into the existing water system. **Caution – do not supply the C Series with heated water. Doing so could damage the cart and the heat will greatly increase the breakdown of ozone back to oxygen, significantly reducing the effectiveness of the cart to sanitize surfaces.**

Ozonated Water Outlet

The ozonated water outlet is a ¾ inch female pipe thread fitting. The C Series can come with an 1.5 inch Tri-Clover fitting already installed, or you can install whichever fitting that allows the C Series to be seamlessly integrated into the existing water system.

Optional Equipment:

Ambient Ozone Level Monitor. An external Ozone Level Monitor is available as an option for the area you want to measure. The monitor will measure ambient level of Ozone in the air. If the monitor senses Ozone in the air above 0.08 ppm, the lights on the control panel will flash on and off. If this happens, the operator should leave the area around the cart and/or increase the amount of ventilation in the area Ozone production will be shut off until the Ozone level in the air drops below 0.08 ppm.

Warning: The Ozone level in the air is only being monitored within the immediate area around the C series. If the water or Ozone gas from the C series is being used in a confined space such as a tank or room that is more than a few feet away from the system, other safety precautions such as increased ventilation, wearing a safety mask and/or using additional Ozone Level monitors should be implemented.

Dissolved Ozone Monitor. A Dissolved Ozone Monitor mounted to the front panel of the system is available as an option. The monitor will measure the level of Ozone dissolved in the water. The Ozone level will be displayed on the screen of the monitor. See the separate instruction manual for the Dissolved Ozone Monitor that is supplied with the system for further information.

ORP Ozone Monitor. An ORP Monitor mounted to the front panel of the system is available as an option. The monitor will measure the measure of the cleanliness of the water & its ability to break down contaminants. The ORP level will be displayed on the screen of the monitor. See the separate instruction manual for the ORP Monitor that is supplied with the system for further information

Theory of Operation

In this section we describe the inner workings of the C Series. The C Series system can be broken up into four sections: Oxygen Concentrator, Ozone Generator, Ozone Injector, and Control Circuitry.

Oxygen Concentrator

ClearWater Tech ozone generators require a source of clean, dry, oil-free, oxygen-enriched air for effective ozone production. To meet that need, ClearWater Tech employs pressure swing adsorption (PSA) technology with an oil-less compressor to increase the concentration of oxygen and reduce the moisture content in the feed gas (the air supplied to the ozone generator). This substantially improves the output capability of the ozone generator and prevents premature failure of key internal components. These air preparation systems deliver 90%+/-3% oxygen purity at -60°F dew point and at very low pneumatic pressures, minimizing noise and reducing compressor wear.

The air preparation system directly affects how many grams of ozone are produced per hour, which in turn also affects the ozone concentration (also known as “percent by weight”). Since ozone is produced with oxygen, the greater the percent of oxygen that enters the ozone generator the greater percent of ozone can be produced. Using a PSA oxygen concentrator allows the C Series to produce ozone at a high grams per hour while also maintaining a high percent by weight. The high percent by weight results in a high solubility of the ozone gas in solution resulting in a high dissolved ozone level.

Ozone Generator

The C Series is equipped with a 2-inch ozone reaction chamber. The oxygen feed gas produced by the air preparation system is supplied to the ozone generator at a maximum pressure of 5 pounds per square inch (psi). It then flows into the built-in air flow meter and then into the ozone cell

The oxygen feed gas enters the fused, thermally protected reaction chamber; some of the oxygen molecules are split while passing through the high voltage electrical field (the “corona”), forming single oxygen atoms (O_1). These oxygen atoms then recombine with other oxygen molecules in the air stream, forming ozone (O_3). ClearWater Tech ozone generators are designed to supply high concentrations of ozone gas. The vacuum created at the ozone injector draws the ozone gas created by the ozone generator into the water line. The ozone generator is equipped with a vacuum switch, which prevents operation if the vacuum from the injector drops below -3 inches of mercury (inHg). This is a safety feature to prevent ozone production if the delivery line to the injector becomes damaged, or if the injector malfunctions.

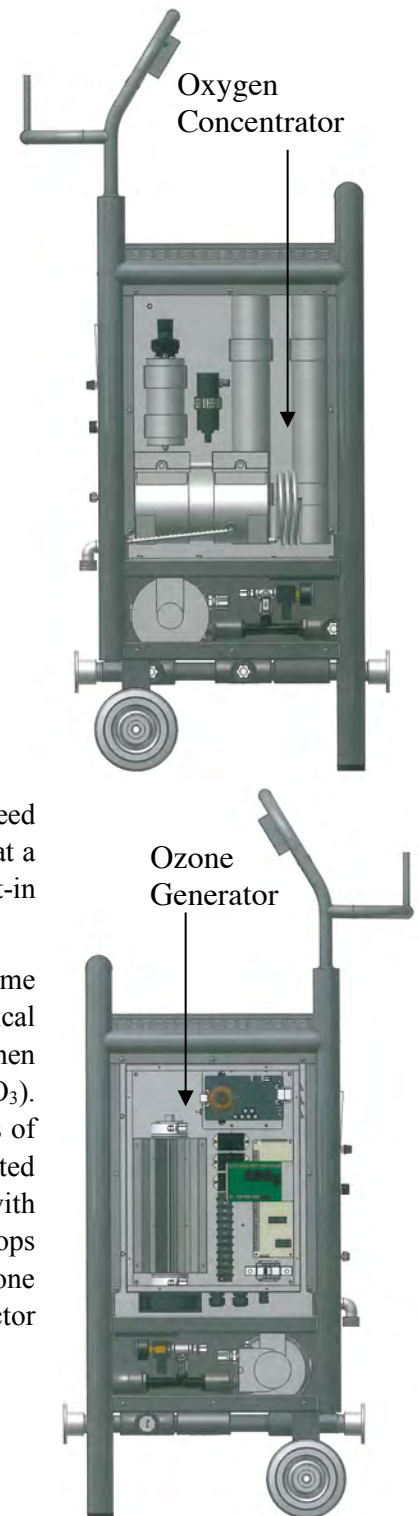

Ozone Injection

The ozone injector serves two purposes: One, it creates the vacuum required to safely draw the ozone gas from the ozone generator and two, it provides a means by which the ozone gas can become dissolved in water. A very dynamic injection process is required to effectively dissolve ozone in water.

ClearWater Tech C Series uses only Mazzei® injectors for maximum mass transfer efficiency. The injector produces a cavitation effect, enabling the ozone gas to join the water stream in the form of extremely tiny bubbles. These bubbles must be as small as possible in order to increase the ratio of bubble surface area to the amount of ozone entering the water.

The Ozone Injector system uses a booster pump to ensure the ozone injector has sufficient pressure to function properly even if the supply pressure is low. This allows the C Series to be more versatile and have a wider operating range.

A Short Course in Fine Bubbles

Lesson 1 – The large bubble (20mm) has a volume of 4.19 cm³ and a surface area of 12.6 cm².

Lesson 2 – 296 small bubbles (3mm) could be made from the large bubble in lesson 1. They would have a total surface area of 83.6cm². This is 6.6 times the surface area of the large bubble.

Lesson 3 – Theoretically, 6.6 times as much water could be ozonated with the same amount of ozone!

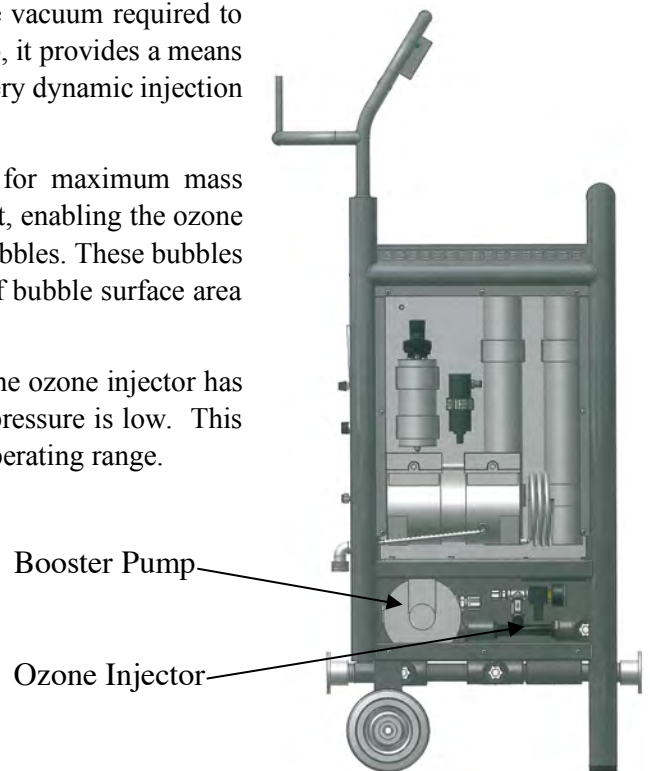

Control Circuitry

The C Series incorporates a sophisticated microcontroller to take in the user input, monitor the ozone generator output, monitor water flow, and monitor oxygen pressure, while allowing the use of less indicator lamps to intelligently provide a large amount data to the operator.

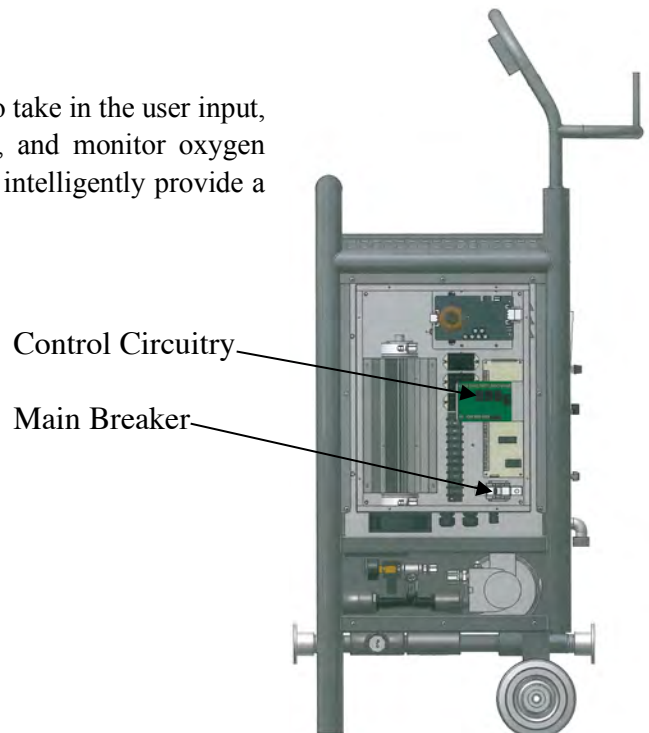

Using the C Series

ClearWater Tech recommends that all personnel who operate or are working nearby Ozone equipment be trained in the safe use of Ozone. Please contact ClearWater Tech to set up training for your personnel.

Ozone is a highly effective disinfectant; however microbial swabbing should be used to ensure that disinfection levels are at a level that meets the requirements for your application. Typically, a 3-5 log (99.9-99.999%) reduction is recommended.

Follow these instructions to use the C Series to produce ozonated water for surface disinfection:

- Step 1:** Plug the C Series into an electrical receptacle.
- Step 2:** Look to make sure the light is illuminated on the GFCI. If the red light is not illuminated press the “Reset” button on the GFCI.
- Step 3:** Connect the water inlet of the C Series to a pressurized source of clean, unheated water. If high flow rates are required (flow rates above 10 GPM), the cart will need to be connected in a side stream configuration. See Figure 3.
- Step 4:** Connect the desired tool to the outlet of the C Series.
- Step 5:** Verify the Gas Valve is in the “Water” position.
- Step 6:** Push the power button, the indicator lamps will cycle On and Off, then the power lamp will remain illuminated.
- Step 7:** Push the mode button until the Ozonated Water mode lamp is illuminated.
- Step 8:** Turn on the water supply, open up any restriction valve at the sanitation tool, and begin sanitizing.

If you need to pause while working and the tool you are using is equipped with a shutoff valve, you may turn off the valve and set down the tool. The C Series will de-energize the booster pump and ozone system, while water is not flowing. If the system remains paused for longer than 10 minutes, the oxygen concentrator will de-energize. Once water flow is detected all of the C Series systems will energize automatically.
- Step 9:** With the water flowing through the C Series, verify that the gas flow-rate through the gas flow meter is indicated in the green zone.
- Step 10:** Once you have finished using the C Series, push the power button to turn off the C Series.

C Series in a Side Stream Configuration

Figure 3



Follow these instructions to use the C Series to produce gas:

- Step 1:** Plug the C Series into an electrical receptacle.
- Step 2:** Look to make sure the light is illuminated on the GFCI. If the red light is not illuminated press the “Reset” button on the GFCI.
- Step 3:** Connect a delivery line to the gas outlet and run the delivery line to where the gas is to be used.
- Step 4:** Verify the Gas Valve is in the “Gas” position.
- Step 5:** Push the power button, the indicator lamps will cycle On and Off, then the power lamp will remain illuminated.
- Step 6:** Push the mode button until either the Oxygen Gas mode or Ozone Gas mode lamp is illuminated depending on which gas type is desired.
- Step 7:** Once you have finished using the C Series, push the power button to de-energize.

Follow these instructions to use the C Series to sanitize barrels:

The barrel should be cleaned using your normal procedure, typically pressurized warm water or wet steam is used to scrub the inside walls. After the removal of tartrates and other debris from the inside of the barrel, you can begin sanitizing with Ozone.

- Step 1:** Plug the C Series cart into an electrical receptacle
- Step 2:** Look to make sure the light is illuminated on the GFCI. If the red light is not illuminated press the “Reset” button on the GFCI.
- Step 3:** Connect the water inlet of the C Series cart to a pressurized source of clean, unheated water. If high flow rates are required (flow rates above 10 GPM), the cart will need to be connected in a side stream configuration. See Figure 3 in the C Series manual.
- Step 4:** Connect the hose and barrel rinse wand to the outlet of the C Series. Place the wand inside the bung hole of the barrel
- Step 5:** Verify the Gas Valve is in the “Water” position. See picture below.

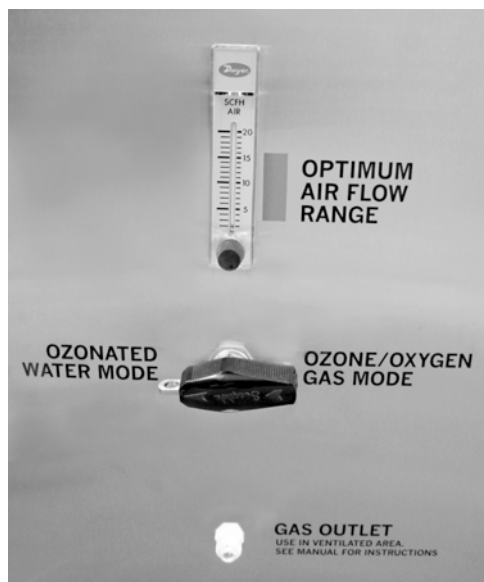

- Step 6:** Push the power button, the indicator lamps will cycle On and Off, then the power lamp will remain illuminated.
- Step 7:** Push the mode button until the Ozonated Water mode lamp is illuminated.
- Step 8:** Turn on the water supply, open up any restriction valve at the sanitation tool, and begin sanitizing.
Barrels with no off odors or microbe contamination should be rinsed for a minimum of 3 minutes.
Barrels with off odors or microbe contamination should be rinsed for a minimum of 5 minutes.
- Step 9:** While water is flowing through the C Series and the Ozonated Water lamp is illuminated, verify that the gas flow-rate through the gas flow meter is indicated in the green zone.
If you need to pause while working and the tool you are using is equipped with a shutoff valve, you may turn off the valve and set down the tool. The C Series will de-energize the booster pump and ozone system, while water is not flowing. If the system remains paused for longer than 10 minutes, the oxygen concentrator will de-energize. Once water flow is detected all of the C Series systems will energize automatically.
- Step 10:** Once you have finished using the C Series system, push the power button to turn off the C Series.

Follow these instructions to use the C Series to prepare barrels for storage:

Ozone gas can be used for barrel storage. The inside of the barrel should be cleaned and rinsed with Ozone, then drained and dry before using Ozone gas to sanitize it.

- Step 1:** Plug the C Series into an electrical receptacle.
- Step 2:** Look to make sure the light is illuminated on the GFCI. If the red light is not illuminated press the “Reset” button on the GFCI.
- Step 3:** Connect a ¼” OD Teflon delivery line to the gas outlet and connect the other end of the line to a barrel gassing bung. The bung should be inserted into the bung hole of the barrel to be sanitized with a tight seal.
ClearWater Tech has available barrel gassing bungs for purchase. There are two types. An “end of the line” type for a single barrel or for the last barrel in a “daisy chain” of multiple barrels to be sanitized. The second type is used in conjunction with the first type to connect multiple barrels in series. Gassing barrels in series will require a longer overall gassing period (see step 6).
- Step 4:** Verify the Gas Valve is in the “Gas” position. See picture below.

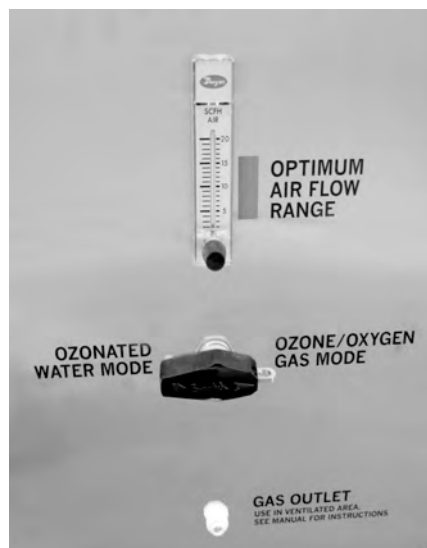

Step 5: Push the power button, the indicator lamps will cycle On and Off, then the power lamp will remain illuminated.

Step 6: Push the mode button until the Ozone Gas mode lamp is illuminated. Verify that the gas flow-rate through the gas flow meter is indicated in the green zone.

It is recommended that the Ozone gas be flowed into the barrels for at least 1 minute each. So for a single barrel, one minute is recommended. For four barrels in series, a total of four minutes should be used. It is recommended that a maximum of six barrels be connected in series. Note: longer periods of barrel gassing will not hurt the barrel.

Step 7: Once you have finished using the C Series system, push the power button to de-energize. Remove the barrel gassing bungs and insert silicone bungs into each of the barrels that were sanitized. ClearWater Tech recommends that this procedure be repeated every 30 days or more frequently if desired.

Follow these instructions to use the C Series to disinfect a room:

WARNING – This feature of the C1 is intended to treat unoccupied spaces only. Plants, animals, and people should not be present when the room is being treated with ozone. High concentrations of the oxidizer ozone will be released into the room being treated.

Step 1: Position the C1 where you want it to be during the ozone treatment (**For best results position the C1 outside the room being treated, run a ¼ Teflon tube from the C1 to the room being treated**).

Step 2: Run ¼ Teflon tube from the C1 gas outlet to the area where ozone will be distributed through the room (a large fan or similar).

Step 3: Plug the C Series into an electrical receptacle.

Step 4: Turn on the C1 by pressing the power button (Far right).

Step 5: Press the mode button (Far left) until the C1 is in the desired mode (Ozone Gas Mode).

Step 6: Press and hold the mode button. At first the mode light will change, but then will shift back to the correct mode. Continue holding the mode button until the air prep shuts down (approximately 10 seconds).

Step 7: The mode light will now begin blinking. The timing sequence begins at 1 hour. To increase the ozone treatment time, press and release the mode button. Each press of the mode button will add 1 hour to the treatment time. As hours are added, the blinking will display the treatment time by quickly blinking the number of hours and then turning off the light for a long pause. The max treatment time is 10 hours.

Step 8: Once the treatment time has been selected, the C1 will wait 1 hour before turning on. After it has been on for the desired treatment time it will automatically turn off.

If at any time you want to start over or cancel this feature simply turn the unit off and back on by pressing the power button (Far right)

Maintenance



Maintenance of the C Series system is critical to its longevity and operating efficiency. While all system components are built to provide years of reliable service with minimum maintenance, following the procedures outlined below is strongly recommended.

All maintenance procedures have been segmented by interval: daily, monthly, semi-annual and annual. Daily procedures involve quick, visual checks for changes in normal operating conditions. Monthly, semi-annual and annual procedures include cleaning and/or replacement of certain critical parts.

NOTES:

- **The ozone generator warranty states that it “does not extend to any product or part which has been damaged or rendered defective as a result of use of parts not sold by ClearWater Tech, or service or unit modification not authorized by ClearWater Tech. Please contact your ClearWater Tech dealer if you have any questions about any maintenance procedure *before* you begin that procedure.**
- **CAUTION: Observe all common safety practices and review the “Safety Warnings and Instructions” section before attempting any maintenance procedure that requires the use of tools and/or shutting down the ozone system.**

Daily Procedures

Control Panel

- Check to make sure the Gas Valve is in the desired position
- When the system is running in Ozonated Water mode with water flowing through the cart, check the gas flow meter’s indicator to make sure the ball is in the green zone. Adjust the needle valve if necessary.

Monthly Procedures

Air Preparation System

- **Cooling Fan Operation:** Check to make sure the cooling fan (mounted on the bottom of the oxygen concentrator plate) is operating. If not, refer to the Troubleshooting Guide.
- **Cooling Fan Filters:** Check the cooling fan filter element (mounted on the fan assembly located at the bottom of the oxygen concentrator plate) and clean as required. Operating conditions in the equipment area will dictate the frequency required for this procedure. Remove the filter element and rinse with water, drying completely before re-installing, (see Figure 4).

Ozone Generator

- **Cooling Fan Operation:** check to make sure the cooling fan (mounted on the bottom of the ozone generator) is operating. If not, refer to the Troubleshooting Guide.
- **Cooling Fan Filters:** Check the cooling fan filter element(s) (mounted on the fan assembly located at the bottom panel of the ozone generator) and clean as required. Operating conditions in the equipment area will dictate the frequency required for this procedure. Remove the filter element and clean with soap and water, drying them completely before re-installing, (see Figure 4). **CAUTION: Unplug the C Series before performing this procedure.**

Ozone Generator Cooling Fan Assembly

Figure 4

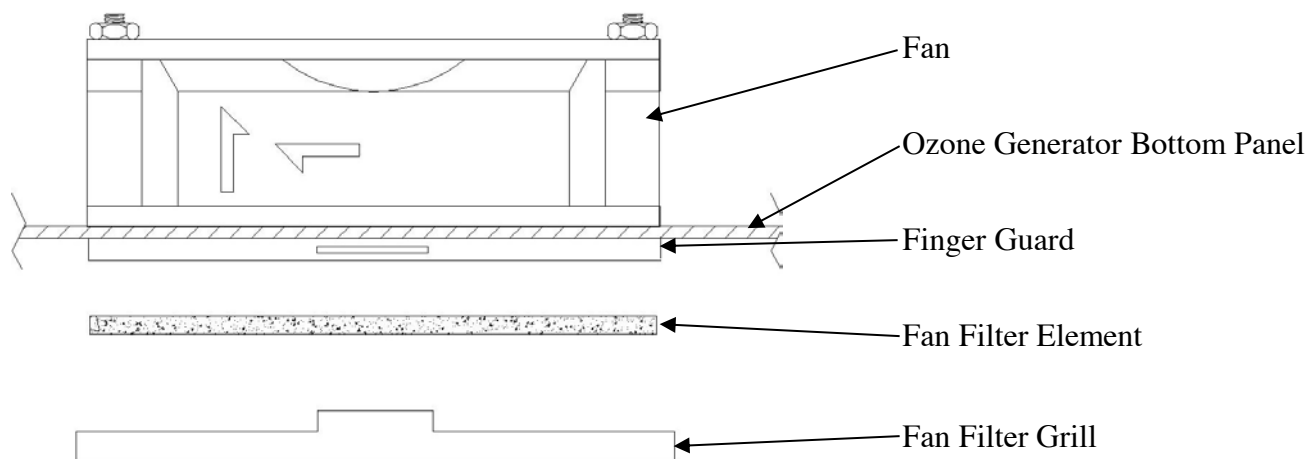

Semi-Annual Procedures

CAUTION: Unplug the C Series before performing any of the following steps.

Air Preparation System

- Air Inlet Filter: Replace the air compressor inlet filter on the air preparation system module (see Appendix A). **Note:** Manufacturers' recommended replacement interval is 4,000 hours of operation. Operating conditions in the equipment area will dictate the required frequency of this procedure.

Annual Procedures

CAUTION: Unplug the C Series before performing any of the following steps.

Air Preparation System

- Compressors: Following the procedures outlined in the compressor rebuild kit, rebuild the two compressor heads (see Appendix A). **Note:** Manufacturers' recommended interval is 5,000 to 12,000 hours of operation. Compressor performance and/or operating conditions in the equipment area will dictate the required frequency of this procedure.

Ozone Generators

- Cooling Fan Filter: Clean or replace the cooling fan filter element as required. **Note:** Operating conditions in the equipment area will dictate the required frequency of this procedure.
- Reaction Chambers: Remove and disassemble the reaction chambers according to the steps outlined below (see Figure 5). Check the chamber interior and dielectric tube for oil, dirt or moisture. **Note:** Disassembly and service of the reaction chamber(s) is a technical, delicate and critical procedure. Please consult your ClearWater Tech dealer before attempting this procedure, or contact the ClearWater Tech service department.

Reaction Chamber Removal and Disassembly

Note: Disassembly and service of the reaction chamber is a technical, delicate and critical procedure. Please consult your ClearWater Tech dealer before attempting this procedure.

Step 1: Unplug the C Series.

Step 2: Disconnect tubing connections from the fittings on both ends of the reaction chamber.

- Step 3:** Disconnect the high voltage lead from the drive transformer.
- Step 4:** Remove the nuts holding the reaction chamber to the chassis.
- Step 5:** Remove reaction chambers from the system.
- Step 6:** Remove retaining screws and washers from the two end caps (4 each) of the reaction chambers.
- Step 7:** Using a gentle back-and-forth twisting motion, remove the non-high voltage end cap (the one without the white power lead attached) from the heat sink/cathode assembly. **Note: Orientation of the end cap on the heat sink/cathode assembly.**
- Step 8:** Remove the high voltage end cap and dielectric from the heat sink/cathode assembly. **Note: Orientation of the end cap on the heat sink/cathode assembly.** Remove end cap and contact brush from dielectric glass anode.
- Step 9:** With contact brush attached, remove the brush adapter nut from the high voltage end cap.
- Step 10:** Inspect the dielectric, end caps and cathode for breakage, corrosion or debris. Clean and/or replace parts as necessary. Re-assemble the reaction chamber per the instructions below.

Reaction Chamber Assembly and Re-installation

- Step 1:** Make sure the glass dielectric is clean (free of dust, dirt, grease, oils, etc.).
- Step 2:** Prepare the end caps for re-assembly by replacing the O-rings. Thread the hex brush adapter nut, with contact brush attached, onto the end of the high voltage end cap (cap with the white power lead attached) center screw.
- Step 3:** Using a gentle twisting motion, press the non-high voltage end cap onto the heat sink/cathode assembly until flush with the heat sink cooling fins. **Note: Orientation of the end cap on the heat sink/cathode assembly.**
- Step 4:** Slide the four end cap retaining screws through the holes in the non-high voltage end cap, aligning them with the heat sink screw bosses. Thread screws into screw bosses until heads are snug against the end cap.
- Step 5:** Roll the high voltage anode (foil-like material) lengthwise, preserving the longer dimension. Insert the rolled anode into the dielectric. Center the anode in the dielectric (approximately 1/2" from either end of the glass), making sure it is rolled squarely.
- Step 6:** Slide the dielectric into the heat sink/cathode assembly. Seat the dielectric into the O-rings of the non-high voltage end cap by applying pressure with a gentle twisting motion. (There must not be any dirt, debris, oils or fingerprints on the dielectric upon re-installation).
- Step 7:** *Slowly* insert the high voltage end cap assembly into the dielectric. **Note: Do not bend center wire of the brush during this procedure.** It is normal for the bristles to bend. Using a gentle twisting motion, press the high voltage end cap onto the heat sink/cathode assembly until flush with the heat sink cooling fins. **Note: Orientation of the end cap on the heat sink/cathode assembly.**
- Step 8:** Slide the four end cap retaining screws through the holes in the end cap, aligning them with the heat sink screw bosses. Thread screws into screw bosses until heads are snug against the end cap.
- Step 9:** Re-install complete reaction chamber assembly into the ozone generator, reconnect the high voltage lead(s) and tubing connections to both end caps. Follow steps outlined in Chapter 7 - "Start-Up and Calibration" to re-start the ozone system.

Reaction Chamber – Exploded View

Figure 5



Troubleshooting

Air Preparation

Problem/Symptom	Possible Cause	Solution
Unit not operating	<ul style="list-style-type: none"> No power to system GFCI is tripped Main Breaker in Control Box is tripped Power button has not been pushed Compressor not functioning 	<ul style="list-style-type: none"> Check main power to system Press the “Reset” button on the GFCI unit Check the Main Breaker, reset if necessary Push the power button Rebuild or replace as required
Low gas flow or no gas flow (gas flow meter, bottom left-hand side of system)	<ul style="list-style-type: none"> Flow meter out of adjustment Fouled compressor inlet filter Compressor not functioning Air leak 	<ul style="list-style-type: none"> Adjust flow meter to get the ball in the green zone Replace inlet filter Rebuild compressor or replace as required Check & tighten fittings
Compressor pressure relief valve making noise	<ul style="list-style-type: none"> Pressure relief valve not operating Pinched tubing Compressor not functioning Sieve bed not operating 	<ul style="list-style-type: none"> Replace pressure relief valve Replace tubing Rebuild compressor or replace as required Repair or replace sieve bed as required
Fan not operating (bottom of the Oxygen Concentrator plate)	<ul style="list-style-type: none"> Debris caught in fan Fan inoperable 	<ul style="list-style-type: none"> Remove debris Replace fan

Control Panel

Problem/Symptom	Possible Cause	Solution
Ozonated Water Mode Lamp Blinking	<ul style="list-style-type: none"> Gas Valve in the wrong position No Water flow through the system Oxygen flow too high 	<ul style="list-style-type: none"> Check the Gas Valve, make sure it is in the “Water” position Check the water source to make sure the inlet water is not being restricted Check the sanitation tool being used to make sure water is not being restricted. Adjust the needle valve on the flow meter to keep the ball in the green zone.
Oxygen Gas Mode Lamp Blinking	<ul style="list-style-type: none"> Gas Valve in the wrong position 	<ul style="list-style-type: none"> Check the Gas Valve, make sure it is in the “Gas” position
Ozone Gas Mode Lamp Blinking	<ul style="list-style-type: none"> Gas Valve in the wrong position 	<ul style="list-style-type: none"> Check the Gas Valve, make sure it is in the “Gas” position
Power Lamp Blinking	<ul style="list-style-type: none"> The System is in need of service 	<ul style="list-style-type: none"> Service the system Call ClearWater Tech Service Department or dealer for assistance. Clear the service alarm by pressing the Power Button while plugging in the C Series and hold down until all of the lights are illuminated.

Ozone Generator

Problem/Symptom	Possible Cause	Solution
Drive Board 12V Main Power, “Green” LED not illuminated	<ul style="list-style-type: none"> No power to drive module from power supply 	<ul style="list-style-type: none"> Check main power to unit Test voltage from power supply to drive module, see Appendix E
Drive Board Transformer (XFMR) Power, “Green” LED not illuminated	<ul style="list-style-type: none"> If drive board “Main Power” LED is not illuminated, the “XFMR Power” LED will not illuminate Blown drive board “on board” fuse Drive board is in “Fault” mode 	<ul style="list-style-type: none"> Test voltage from power supply to drive module, see Appendix E Replace “on board” fuse See Troubleshooting, “Fault” LED
Drive Board Ozone Output, “Amber” LED not illuminated	<ul style="list-style-type: none"> If the Transformer (XFMR) Power LED is not illuminated, the “Ozone Output” LED will not illuminate Drive board is in “Fault” mode 	<ul style="list-style-type: none"> Check all wires and connectors See Troubleshooting, “Fault” LED
Drive Board System Fault – Single Flash The drive board cannot get enough power into the reaction chamber.	<ul style="list-style-type: none"> Loose wire harness connection from the drive board to the drive transformer Drive board incorrectly characterized the system on startup Loose or disconnected High Voltage Lead to transformer Excessive dirt or debris in ozone reaction chamber Water in ozone reaction chamber Broken dielectric Failed drive board Failed drive transformer 	<ul style="list-style-type: none"> Check all wires and connectors With pressure and flow at normal operating conditions, restart the ozone generator. Attach High Voltage Lead to transformer Clean the dielectric and replace O-rings Clean the dielectric and replace O-rings Replace dielectric Replace drive board Replace drive transformer
Drive Board System Fault – Double Flash The drive board’s feedback had a series of sudden dips indicative of unusual arcing occurring somewhere in the system.	<ul style="list-style-type: none"> Loose wire harness connection from the drive board to the drive transformer Loose or disconnected High Voltage Lead to transformer Excessive dirt or debris in ozone reaction chamber Water in ozone reaction chamber Broken dielectric Failed drive board Failed drive transformer 	<ul style="list-style-type: none"> Check all wires and connectors Attach High Voltage Lead to transformer Clean the dielectric and replace O-rings Clean the dielectric and replace O-rings Replace dielectric Replace drive board Replace drive transformer
Drive Board System Fault – Triple Flash The thermal switch on the board has closed indicating that it was exposed to temperatures exceeding 140F.	<ul style="list-style-type: none"> Unit is overheating 	<ul style="list-style-type: none"> Check fan for proper operation and clean fan filter Check operating temperature See “Installation Procedures – Getting Started, Equipment Placement”
Fan not operating	<ul style="list-style-type: none"> Fan obstructed Fan inoperable 	<ul style="list-style-type: none"> Remove obstruction Replace fan
Unit flooded with water	<ul style="list-style-type: none"> Defective check valve Hydraulics out of adjustment 	<ul style="list-style-type: none"> Assess damage, repair as required, replace check valve See ‘Start-Up & Calibration’

Ozone Generator – Continued

Problem/Symptom	Possible Cause	Solution
Ozone smell detected from or near ozone generator	<ul style="list-style-type: none"> • Gas Valve in the wrong position • Loose internal fittings • Defective O-ring seals in reaction chamber • Defective dielectrics 	<ul style="list-style-type: none"> • Check the Gas Valve, make sure it is in the appropriate position • Check all fittings, tighten as required • Check & replace as required • Check & replace as required

Ozone Injection

Problem/Symptom	Possible Cause	Solution
Water backflow past injector check valve	<ul style="list-style-type: none"> • Defective injector check valve 	<ul style="list-style-type: none"> • Replace injector check valve
No vacuum at venturi inlet port of ozone injector	<ul style="list-style-type: none"> • Low gpm water flow through ozone injector • Back pressure in hydraulic line • Booster pump not functioning properly 	<ul style="list-style-type: none"> • Check for obstruction upstream • Check for obstructions downstream of ozone injector • Check booster pump (contact dealer)
Ozone smell detected in or around ozone injector	<ul style="list-style-type: none"> • Gas Valve in the wrong position • Loose fittings • Broken fittings 	<ul style="list-style-type: none"> • Check the Gas Valve, make sure it is in the appropriate position • Check all fittings, tighten as required
Low water flow or no water flow	<ul style="list-style-type: none"> • Restriction at the source • Restriction at the tool • Pump not functioning 	<ul style="list-style-type: none"> • Remove the obstruction or restriction. • Add pre-filter to remove debris from source water. • Check tool, back flush tool, use a different tool. • Replace the pump, contact ClearWater Tech Service Department or dealer for assistance

Appendix A – Specifications

Left Side View

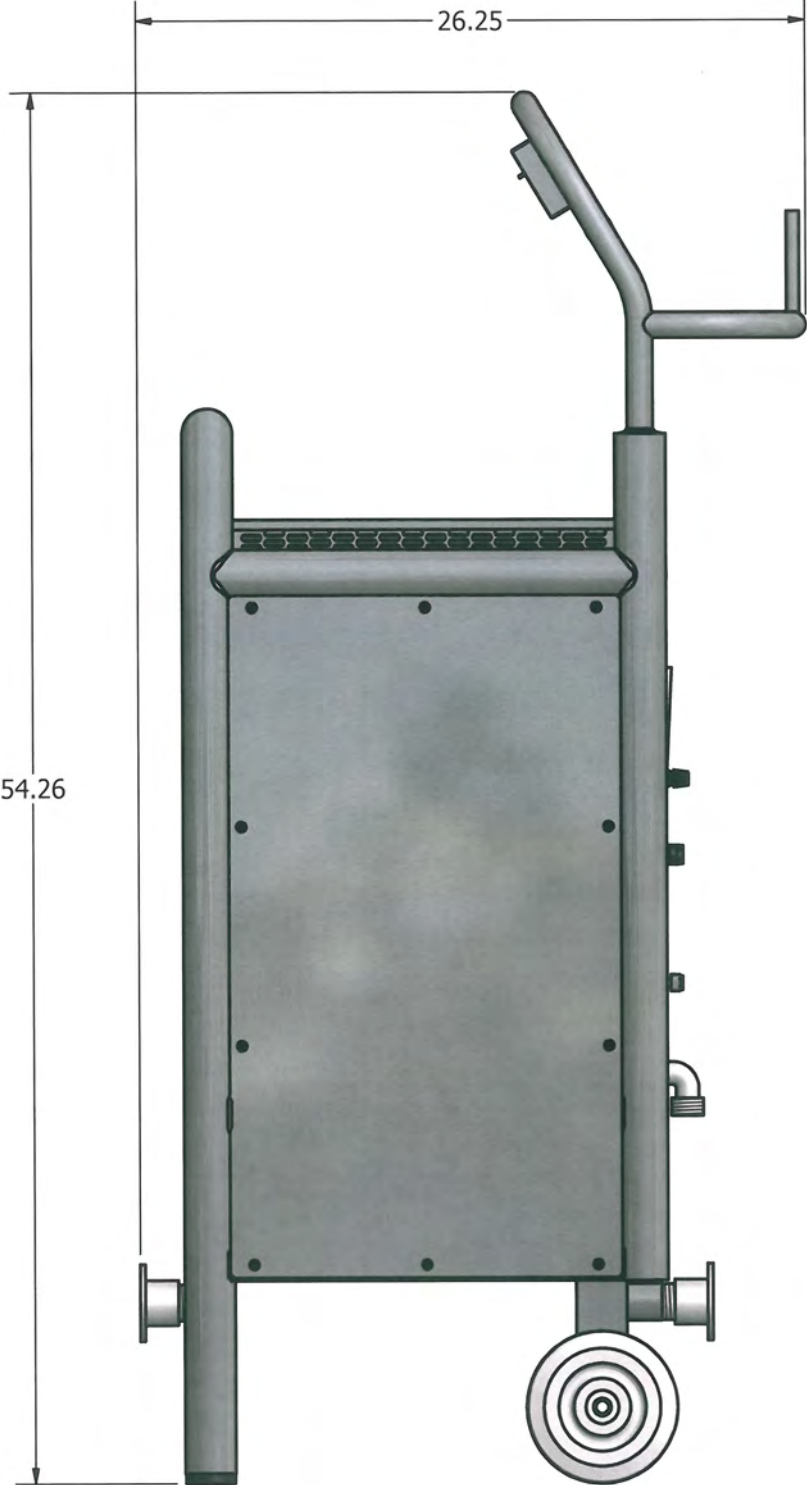

Front View



Left Side View

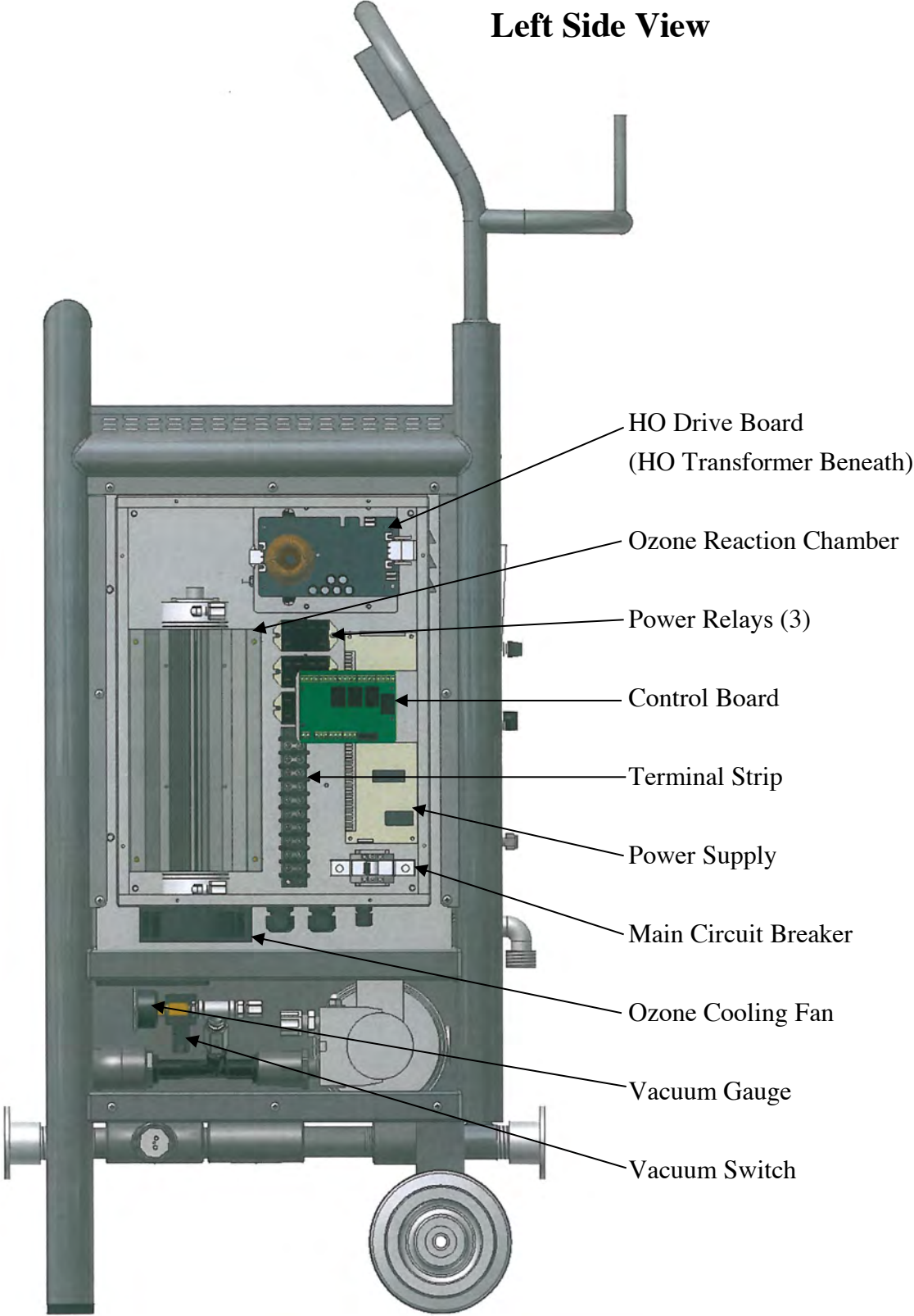

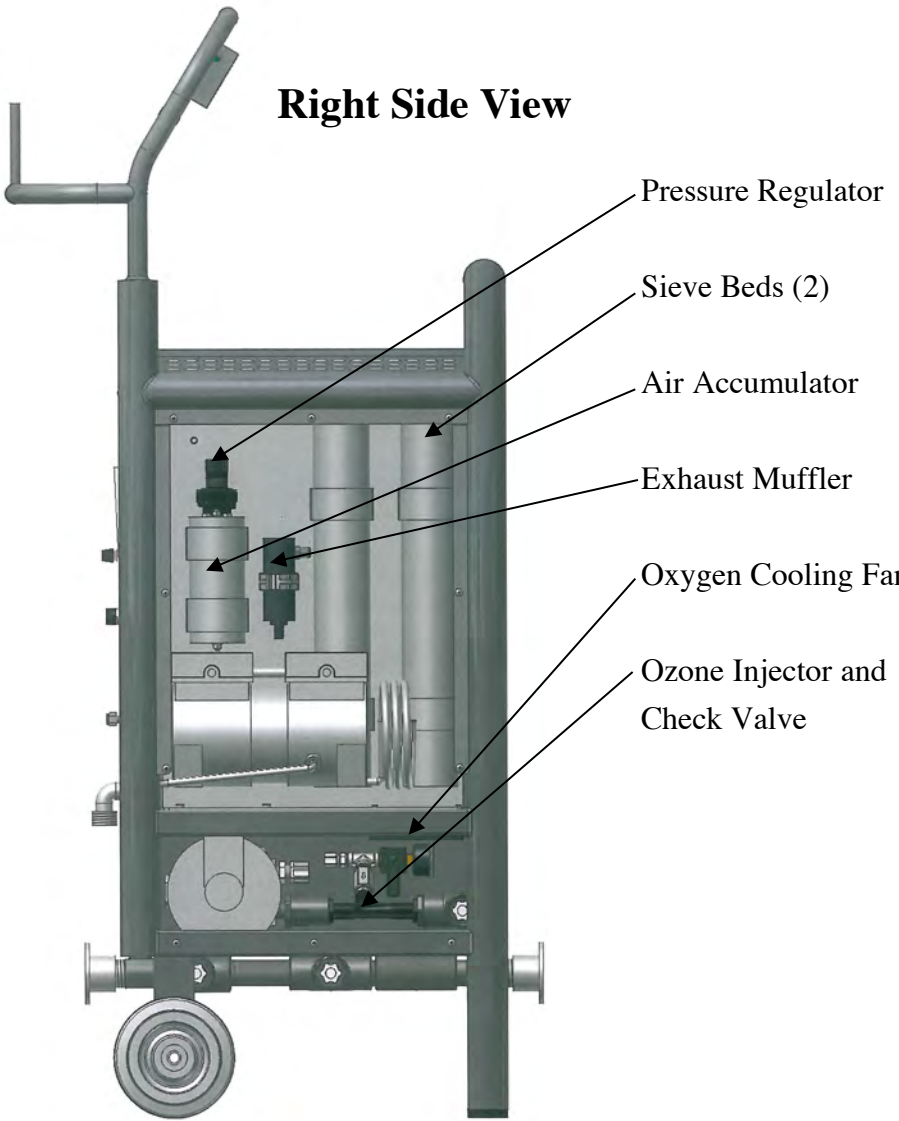

- Pressure Regulator
- Sieve Beds (2)
- Air Accumulator
- Exhaust Muffler
- Oxygen Cooling Fan
- Ozone Injector and Check Valve

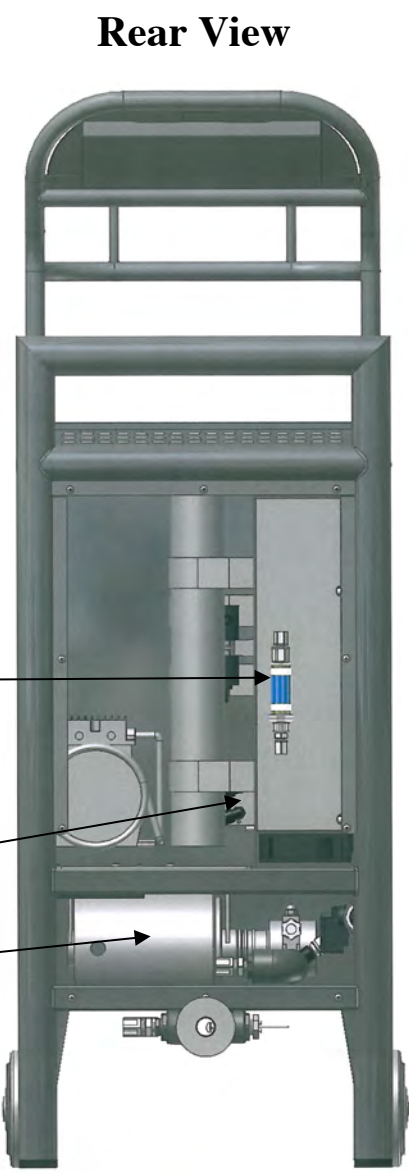

- Desiccant Air Filter
- Solenoid Valve
- Booster Pump

Main Power	C1: 120 VAC 60 Hz, 12 amps C2: 220/240 VAC 50/60 Hz, 7 amps
Power cord	10 feet with GFCI
Dissolved Ozone	8 PPM @ 10 GPM
Ozone gas	18 g/hr. @ 12 SCFH 4% concentration by weight
Oxygen gas	>90% +/- 3% @ 15 SCFH
Water inlet pressure	40-80 PSI
Water inlet flow	10 GPM
Water inlet temperature	100 F maximum
Water pH	7.0 to 7.6 pH for maximum Ozone output
Water Connections	Tri-Clover stainless steel fittings for water inlet/outlet.
Gas Connections	¼” Kynar push to connect for Ozone/Oxygen gas outlet.
Indicators	Power On, Ozone On, Ozone/Water, Oxygen Gas and Ozone Gas. Gas Flow meter.
Controls	Power On/Off Button. Mode select switch
Outside dimensions	54.3” H X 20.6” W X 26.3” D
Weight	160 lbs
Options	Water Hoses Barrel Washers Tri-Clover Fittings ORP Monitor Dissolved Ozone Monitor Ambient Ozone Monitor Dissolved Ozone Test Kit

Appendix B – Parts List

Description	Part Number
Solenoid Valve Assembly	OXU379
Compressor 120VAC 60Hz	OXU340
Compressor 220/240 VAC 50/60Hz	OXU374
Inlet Filter Package	OXU371
Maintenance Kit – Cooling Fan Filter, Inlet Filter	ASP75A
Rebuild Kit – Sieve Bed, Solenoid Valve, Inlet Filter, Cooling Fan Filter	ASP76A
Reaction Chamber	RCC7
Dielectric Anode 2”	RCC73
Non-High Voltage End Cap	RCC107
High Voltage End Cap	RCC102
O-ring Set	ORS30
Power Supply – 48VDC, 300W	PSR822
Drive Module Transformer	HVT275
Drive Module Board	CCA1232
Control Board	CCA1347WC
Cooling Fan Filter	FA40
Vacuum Switch	SWT90SA
Fuse, Littelfuse Minifuse 297005 – 5 amp, 32VAC, Drive Board	FUS75
Cooling Fan 120VAC	FA41
Cooling Fan 240VAC	FA42

Appendix C – Maintenance Kit

Maintenance Kit – C Series		
Part Number	Quantity	Description
FA40	1	Filter – Cooling Fan Filter
ORG10	4	O-Ring – 2” CD Reaction Chamber, Small
ORG110	4	O-Ring – 2” CD Reaction Chamber, Large
FUS75	2	Fuse, Littlefuse Minifuse 297005 – 5 amp, 32VAC, Drive Board
CKV21	1	Check Valve – PVC ¼ FPT X ¼ FPT, Teflon Ball Viton Seals
OXS350	1	Inlet Air Filter

Appendix D – Logic Schematics

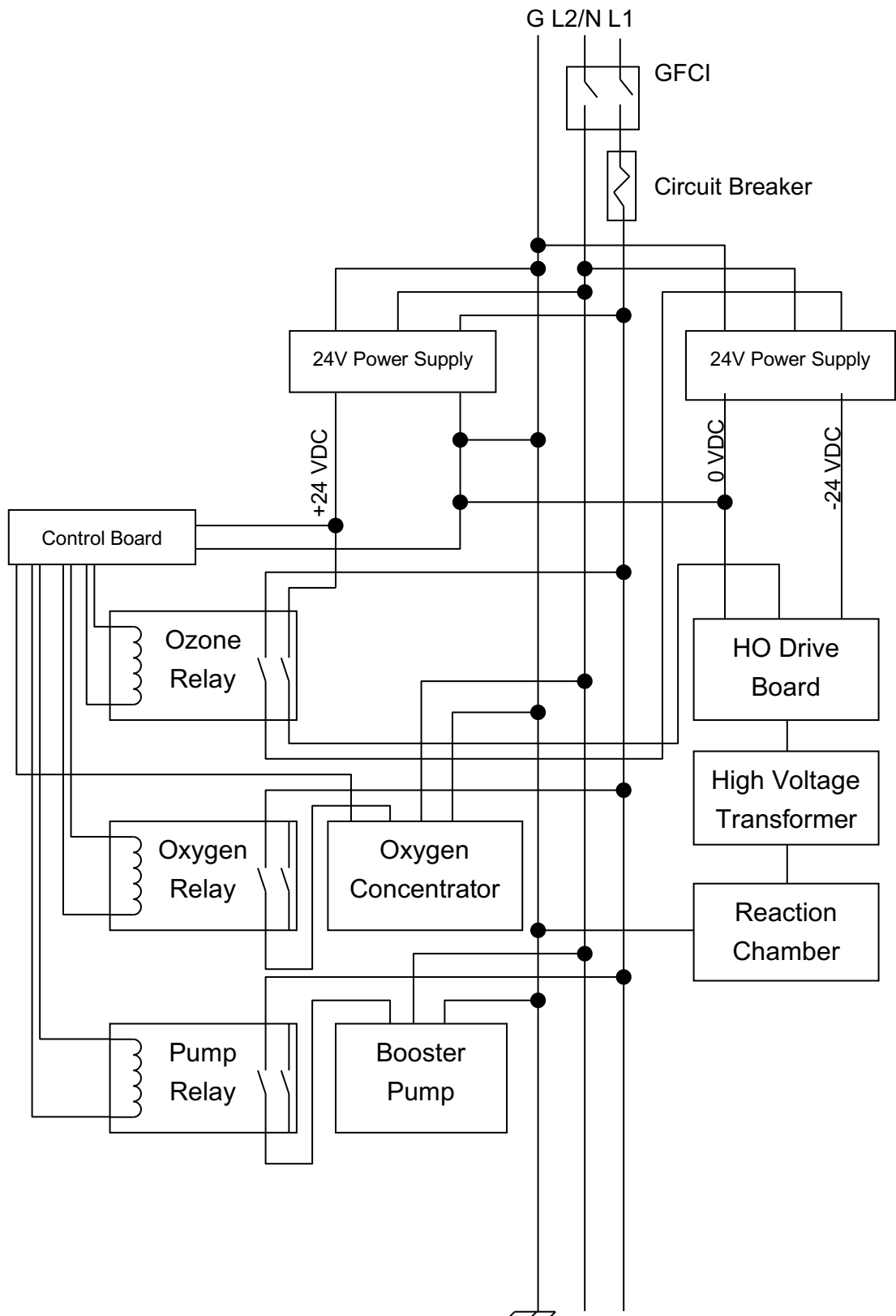

Appendix E – Drive Module Input Voltages

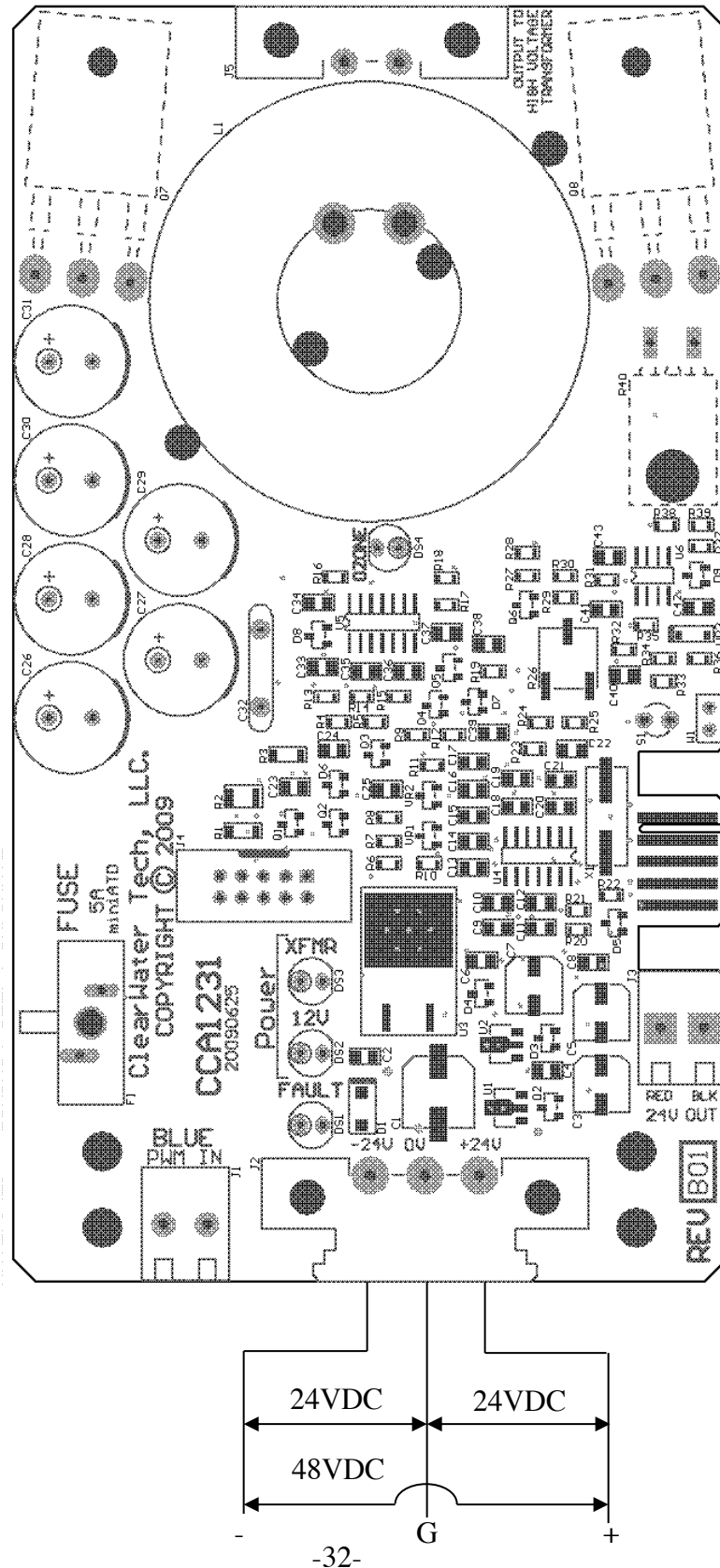

Appendix F – Material Safety Data Sheet

Product Name:	Ozone	This MSDS complies with OSHA's Hazard Communication Standard, 29 CFR 1910 1200 and OSHA form 174		
Section I				
Manufacturer's name: ClearWater Tech		Emergency Telephone Number: (805) 546-2333		
Address: 850 Capitolio Way San Luis Obispo, CA 93401		Telephone Number for Information: (805) 549-9724		
		Date Prepared:	7/2/2013	
Section II—Hazardous Ingredients/Identity Information				
Hazardous Components:	OSHA PEL	ACGIH TLV	Other Limits	%
Ozone	0.1 PPM	0.1 PPM	NIOSH 0.1 PPM	NA
Section III—Physical/Chemical Characteristics				
Boiling Point:	-169 F	Specific Gravity:	NA	
Vapor Pressure (mm Hg):	760	Freezing Point:	NA	
Vapor Density (AIR = 1):	1.6	Evaporation Rate:	N/A	
Solubility in Water:	570 mg/l @ 20 C			
Appearance and Odor:	Clear at low concentrations, blue at higher concentrations. Aseptic odor.			
Section IV—Fire and Explosion Hazard Data				
Flash Point:	N/A	Flammable Limits:	LEL: NA	UEL: N/A
Extinguishing Media:	Use extinguishing agents suitable for surrounding fire			
Special Fire Fighting Procedures:	Wear self-contained breathing apparatus			
Unusual Fire and Explosion Hazards:	Container may explode in heat of fire.			
Section V—Reactivity Data				
Stability	Unstable	X	Conditions to Avoid: None Known	
	Stable			
Incompatibility:	Natural rubber may degrade over extend periods of exposure			
Hazardous Decomposition or Byproducts:	None			
Hazardous Polymerization:	May Occur		Conditions to Avoid: None Known	
	Will Not Occur	X		

Section VI—Health Hazard Data					
Route(s) of Entry	Inhalation X	Skin X	Ingestion No	Eye X	Hazardous No
Health Hazards					
Acute: Mild skin, eye, nose, throat, respiratory tract irritation					
Chronic: May cause breathing disorders.					
Carcinogenicity: No	NTP: No	IARC Monographs: No	OSHA Regulated: No		
Signs and Symptoms of Exposure:					
Mild eye or lung irritation if exposed for extended periods of time. Drying or mild irritation of the skin if exposed for extended periods of time.					
Medical Conditions Generally Aggravated by Exposure:			Chronic Pulmonary Problems		
Emergency and First Aid Procedures: Get fresh air, flush eyes with water					
Section VII—Precautions for Safe Handling and Use					
Steps to Be Taken in Case Material Is Released or Spilled: Ventilate area					
Waste Disposal Method: Treat with Ozone destruct unit before releasing into atmosphere					
Precautions to Be Taken in Handling and Storing: None					
Other Precautions: N/A					
Section VIII—Control Measures					
Respiratory Protection: Not required for normal use					
Ventilation:		Local: Exhaust	Special	N/A	
		General: Exhaust	Other	N/A	
Protective Gloves: Not required		Eye Protection: Not required			
Other Protective Clothing or Equipment:		Not required			
Work/Hygienic Practices:		N/A			

This material safety data sheet is provided as an information resource only. It should not be taken as a warranty or representation for which the preparer assumes legal responsibility. While we believe the information contained herein is accurate and compiled from sources believed to be reliable, it is the responsibility of the user to investigate and verify its validity. The buyer assumes all responsibility of using and handling the product in accordance with applicable federal, state, and local regulations.

Appendix G— Warranty Information

ClearWater Tech, LLC. Limited Three-Year Warranty

Summary of the Warranty

ClearWater Tech, LLC (“CWT”) makes every effort to assure that its products meet high quality and durability standards and warrants the products it manufactures against defects in materials and workmanship for a period of three (3) years, commencing on the date of original shipment from CWT, with the following exceptions: 1) The warranty period shall begin on the installation date if the installation is performed within 90 days of the original shipment from CWT; 2) The warranty period shall begin on the date of the bill of sale to the end user if the installation date is more 90 days after the original shipment date. Repairs and replacement parts provided under this warranty shall carry only the unexpired portion of this warranty or 90 days, whichever is longer.

Warranty Validation and Registration

To validate the warranty, the product must be registered either by; filling out the warranty card provided and returning it to CWT by mail or registering the product on-line at warranty.cwtozone.com. Scanning the QR Code, with a mobile device, will link directly to the Product Warranty Registration form located on the CWT website.

To obtain validation of the 3-year limited warranty; the CWT product(s) must be installed and operated within usage parameters stated, and service intervals performed as specified in the product(s) I/O manual. Failure to do so will void warranty.

Scan to Register
Product Online



Items Excluded from the Warranty

This warranty does not extend to any product and/or part from which the factory assigned serial number has been removed or which has been damaged or rendered defective as a result of:

- An accident, misuse, alteration or abuse
- An act of God such as flood, earthquake, hurricane, lightning or other disaster resulting only from the forces of nature
- Normal wear and tear
- Operation outside the usage parameters stated in the product I/O manual
- Oxygen systems and Ozone sensors have a one (1) year warranty
- Use of parts not sold by CWT
- Service or unit modification not authorized by CWT
- Check valve/solenoid valve failure
- Damage, which may occur during shipping
- Service or maintenance parts outlined within the I/O manual
- Equipment not manufactured by CWT will carry the OEM’s factory warranty

Obtaining Service Under the Warranty

Any product and/or part not performing satisfactorily may be returned to CWT for evaluation. A Return Goods Authorization (RGA) number must first be obtained by either calling or writing your local authorized dealer, distributor, or CWT direct, prior to shipping the product. The problem experienced with the product and/or part must be clearly described. The RGA number must appear prominently on the exterior of the shipped box(es). The product and/or part must be packaged either in its original packing material or in comparable and suitable packing material, if the original is not available. You are responsible for paying shipping charges to CWT and for any damages to the product and/or part that may occur during shipment. It is recommended that you insure the shipment for the amount you originally paid for the product and/or part.

If, after the product and/or part is returned prepaid and evaluated by CWT, it proves to be defective while under warranty, CWT will, at its election, either repair or replace the defective product and/or part and will return ship at lowest cost transportation prepaid to you **except for shipments going outside the 50 states of the United States of America**. If upon inspection, it is determined that there is no defect or that the damage to the product and/or part resulted from causes not within the scope of this limited warranty, then you must bear the cost of repair or replacement of damaged product and/or part and all return freight charges. Any unauthorized attempt by the end user to repair CWT manufactured products without prior permission shall void any and all warranties. For service, contact your authorized dealer or distributor or CWT direct at (805) 549-9724.

Exclusive Warranty

There is no other expressed warranty on CWT products and/or parts. Neither this warranty, nor any other warranty, expressed or implied, including any implied warranties or merchantability of fitness, shall extend beyond the warranty period. Some states do not allow limitation on how long an implied warranty lasts, so that the above limitation or exclusion may not apply to you.

Disclaimer of Incidental and Consequential Damages

No responsibility is assumed for any incidental or consequential damages; this includes any damage to another product or products resulting from such a defect. Some states do not allow the exclusion or limitation of incidental or consequential damages, so that above limitation or exclusion may not apply to you.

Legal Remedies of Purchaser

This warranty gives you specific legal rights and you may also have other rights, which vary from state to state.

THIS STATEMENT OF WARRANTY SUPERSEDES ALL OTHERS PROVIDED TO YOU AT ANY PRIOR TIME.